

Constructive counterexamples to the additivity of minimum output Rényi entropy of quantum channels for all $p > 1$

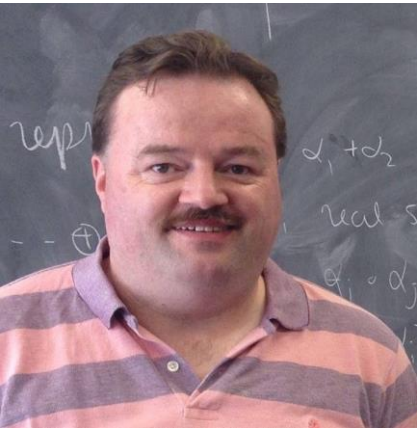

Harm Derksen
Northeastern University

and

Benjamin Lovitz
Concordia University

Quantum states and channels

Let $A = \mathbb{C}^n$.

Quantum states / Density operators: $D(A) := \{\rho \in \text{Mat}_{n \times n} : \rho \geq 0, \text{Tr}(\rho) = 1\}$

Qtm channel $\Phi: D(A) \rightarrow D(B)$ is a map of the form $\Phi(\rho) = \text{Tr}_E(V\rho V^\dagger)$
for some isometry $V: A \rightarrow B \otimes E$

Def: For a unit vector $|\psi\rangle \in B \otimes E$,
and $\psi := |\psi\rangle\langle\psi| \in D(B \otimes E)$
 $\psi_B := \text{Tr}_E(\psi) \in D(B)$

Classical capacity of a quantum channel

Let $\Phi: D(A) \rightarrow D(B)$ be a quantum channel.

$C(\Phi) := \#$ classical bits/channel use that can be sent through Φ

$= \max R$ s.t. $\exists m_k, \delta_k, \mathcal{E}_k, \mathcal{D}_k$ satisfying:

1. $R = \lim_{k \rightarrow \infty} \frac{m_k}{k}$ **#Bits/channel use**

2. $\forall x \in \{0,1\}^{m_k}, \Pr\left(\left(\mathcal{D}_k \circ \Phi^{\otimes k} \circ \mathcal{E}_k\right)(x) = x\right) \geq 1 - \delta_k$

3. $\lim_{k \rightarrow \infty} \delta_k = 0$

s.t. \approx holds

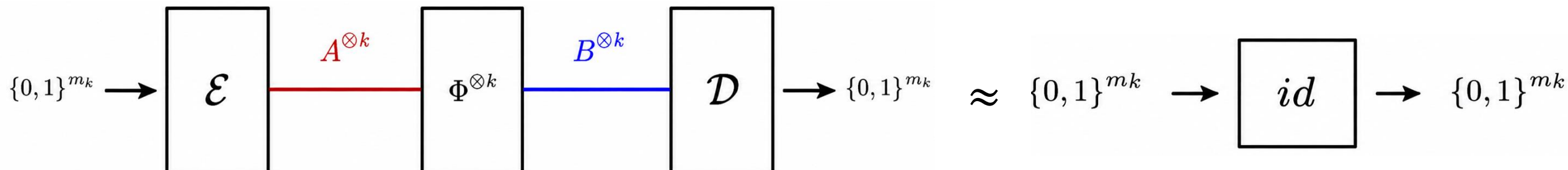

Classical capacity of a quantum channel

Let $\Phi: D(A) \rightarrow D(B)$ be a quantum channel.

$C(\Phi) := \#$ classical bits/channel use that can be sent through Φ

Known: $C(\Phi) = \lim_{k \rightarrow \infty} \frac{\chi(\Phi^{\otimes k})}{k}$ [Holevo 98, Schumacher-Westmoreland 97]

Unknown: Does it hold that $C(\Phi \otimes \Psi) = C(\Phi) + C(\Psi)$?

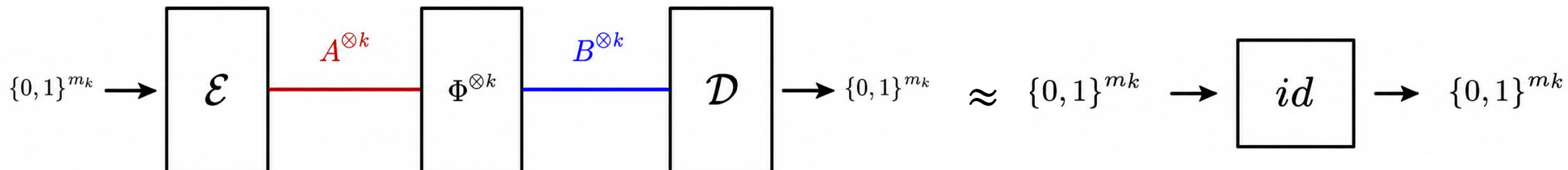

Entanglement assisted classical capacity

Let $\Phi: D(A) \rightarrow D(B)$ be a quantum channel.

$C_E(\Phi) := \# \text{ bits/channel use w/ pre-shared ent.}$

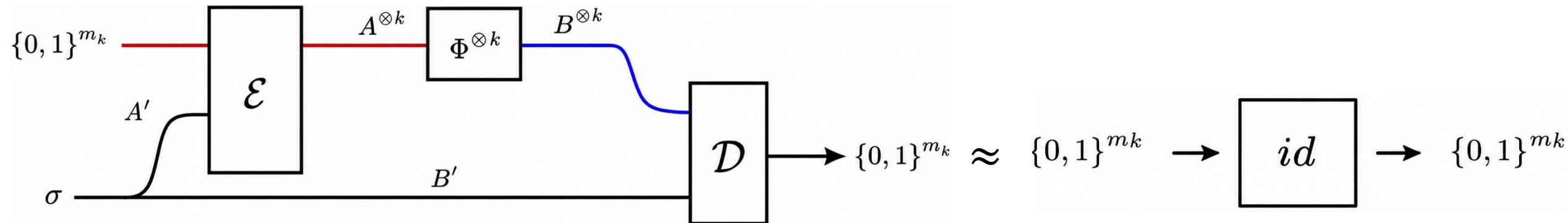

Known:

$$C_E(\Phi) = \max_{\sigma \in D(A)} (H(\sigma) + I_c(\sigma; \Phi))$$

[Bennett-Shor-Smolín-Thapliyal 99]

$$C_E(\Phi \otimes \Psi) = C_E(\Phi) + C_E(\Psi)$$

[Bennett-Shor-Smolín-Thapliyal 02]

Quantum capacity

Let $\Phi: D(A) \rightarrow D(B)$ be a quantum channel.

$Q(\Phi) := \# \text{qubits/channel use}$

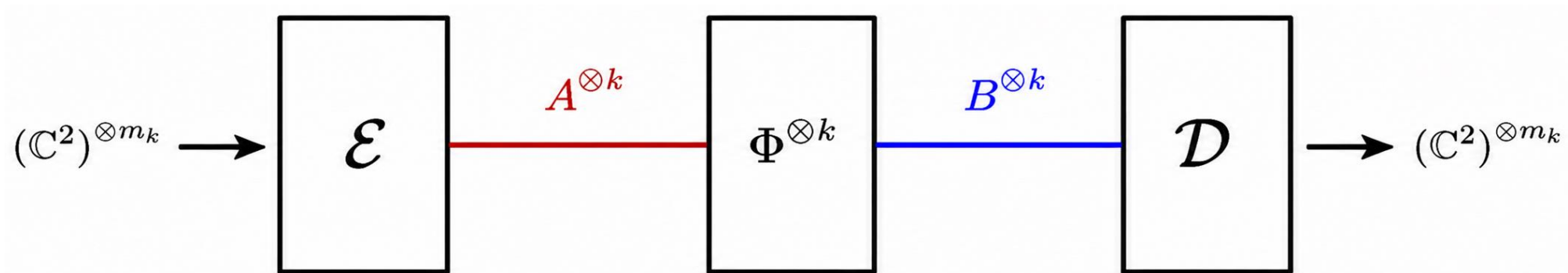

Known:

$$Q(\Phi) = \lim_{k \rightarrow \infty} I_c(\Phi^{\otimes k})$$

[Devetak 05]

There exist Φ, Ψ with $Q(\Phi \otimes \Psi) > Q(\Phi) + Q(\Psi)$

[Smith-Yard 08]

Entanglement-assisted quantum capacity

$$Q_E(\Phi) =$$

Entanglement-assisted quantum capacity

$$Q_E(\Phi) = \frac{C_E(\Phi)}{2}$$

This talk: Classical capacity

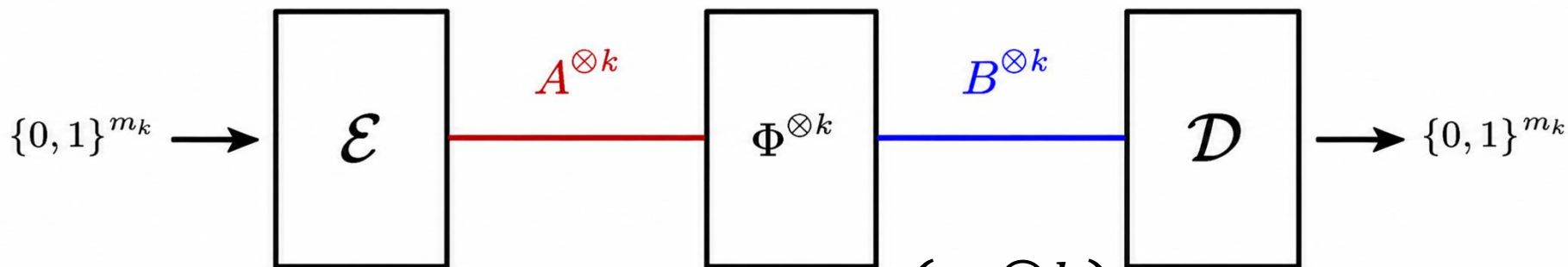

$$C(\Phi) = \lim_{k \rightarrow \infty} \frac{\chi(\Phi^{\otimes k})}{k}$$

Yes, but I can't find an explicit example

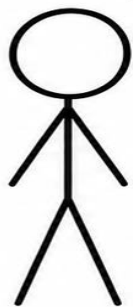

Hastings

Is the limit $k \rightarrow \infty$ necessary?

We can't either... but almost!



Derksen



Lovitz

The Holevo-Schumacher-Westmoreland (HSW) Theorem

Holevo information: $\chi(\{p_i, \rho_i\}) := H(\sum_i p_i \rho_i) - \sum_i p_i H(\rho_i)$, $H(\rho) := -\text{Tr}(\rho \log \rho)$

Holevo capacity: $\chi(\Phi) := \max_{\{p_i, \rho_i\}} \chi(\{p_i, \Phi(\rho_i)\})$

Theorem: [H 98, SW 97] $C(\Phi) = \lim_{k \rightarrow \infty} \frac{\chi(\Phi^{\otimes k})}{k}$

The Additivity Conjecture

Additivity Conjecture: $\chi(\Phi \otimes \Psi) = \chi(\Phi) + \chi(\Psi)$ for any Φ, Ψ (Hence $C(\Phi) = \chi(\Phi)$)
(\geq is obvious)

Counterexample: [Hastings 09] Random Φ satisfies $\chi(\Phi \otimes \Phi) > 2 \chi(\Phi)$

Open question: Find explicit Φ with $\chi(\Phi \otimes \Phi) > 2 \chi(\Phi)$

(hence $C(\Phi) > \chi(\Phi)$)

Minimum Output Entropy (MOE)

Rényi p -entropy: For $p > 1$, let $H^{(p)}(\rho) := \frac{1}{1-p} \log \text{Tr}(\rho^p)$

Further, let $H^{(1)}(\rho) := \lim_{p \rightarrow 1} H^{(p)}(\rho)$ **Fact:** $H^{(1)}(\rho) = H(\rho)$

Min output p -entropy: $H_{\min}^{(p)}(\Phi) := \min_{|\psi\rangle} H^{(p)}(\Phi(\psi))$

Theorem: [Shor 04] The following statements are equivalent.

1. $\chi(\Phi \otimes \Psi) = \chi(\Phi) + \chi(\Psi)$ for all Φ, Ψ
2. $H_{\min}^{(1)}(\Phi \otimes \Psi) = H_{\min}^{(1)}(\Phi) + H_{\min}^{(1)}(\Psi)$ for all Φ, Ψ
(\leq is obvious)

Historically, additivity conjecture mostly studied through MOE (#2).

Some prior work on the additivity conjecture

Cases when the conjecture holds:

$$H_{\min}^{(1)}(\Phi \otimes \Psi) = H_{\min}^{(1)}(\Phi) + H_{\min}^{(1)}(\Psi) \quad \text{whenever } \Phi \text{ is:}$$

- Identity channel [Asomov-Holevo 01], Unital qubit channel [King 02], Entanglement breaking channel [Shor 02], Depolarizing channel [King 03], ...

Negative results:

Random channel Φ for which $H_{\min}^{(p)}(\Phi \otimes \Phi) < 2H_{\min}^{(p)}(\Phi)$:

- For $p > 1$ [Hayden-Winter 08]
- For p close to zero [Cubitt-Harrow-Leung-Montanaro-Winter 08]
- For $p = 1$ [Hastings 09]

Explicit channel Φ for which $H_{\min}^{(p)}(\Phi \otimes \Phi) < 2H_{\min}^{(p)}(\Phi)$:

- For $p > 4.79$ [Werner-Holevo 02]
- For $p > 2$ [Grudka-Horodecki-Pankowski 10, Szczygielski-Studziński 24]
- For $p > 1$ [Derksen-Lovitz 25]

Main result: [Derksen-Lovitz 25]

For any $p > 1$, an explicit channel Φ on $\tilde{O}\left(\frac{1}{p-1}\right)$ qubits

such that

$$H_{\min}^{(p)}(\Phi \otimes \Phi) < 2H_{\min}^{(p)}(\Phi).$$

p	In #qubits	Out #qubits
2	10	5
1.5	13	7
1.25	28	14
1.125	66	33
1.0625	153	77

Main result: [Derksen-Lovitz 25]

For any $p > 1$, an explicit channel Φ on $\tilde{O}\left(\frac{1}{p-1}\right)$ qubits

such that

$$H_{\min}^{(p)}(\Phi \otimes \Phi) < 2H_{\min}^{(p)}(\Phi).$$

Proof ingredients:



- Channels \rightarrow Subspaces
- Useful bounds on $H_{\min}^{(p)}$
- Entangled subspace construction [Beauzamy+ 90]

Linear algebra refresher

Def: A **subspace** is a subset $U \subseteq B \otimes E$ of the form $U = \text{span}\{v_1, \dots, v_\ell\}$
for some $v_1, \dots, v_\ell \in B \otimes E$

Example: For a matrix $V = (v_1, \dots, v_\ell)$,
the image $\text{Im}(V) := \text{span}\{v_1, \dots, v_\ell\}$ is a subspace.

Channels \rightarrow Subspaces

Def: For a subspace $U \subseteq B \otimes E$, let $H_{\min}^{(p)}(U) := \min_{|\phi\rangle \in U} H^{(p)}(\phi_B)$

Lemma: Let $\Phi(\rho) = \text{Tr}_E(V\rho V^\dagger)$ and let $U := \text{im}(V) \subseteq B \otimes E$.

Then $H_{\min}^{(p)}(\Phi) = H_{\min}^{(p)}(U)$

Proof:

$$H_{\min}^{(p)}(\Phi) = \min_{|\psi\rangle \in \mathcal{E}_A} H^{(p)}(\Phi(\psi)) = \min_{|\psi\rangle \in \mathcal{E}_A} H^{(p)}(\text{Tr}_E(V\psi V^\dagger)) = \min_{|\phi\rangle \in U} H^{(p)}(\phi_B) = H_{\min}^{(p)}(U) \quad \checkmark$$

New goal: Construct subspace $U \subseteq B \otimes E$ s.t. $H_{\min}^{(p)}(U \otimes U) < 2H_{\min}^{(p)}(U)$

$$U \otimes U \subseteq (B \otimes B) \otimes (E \otimes E)$$

Main result: [D-L 25] For any $p > 1$, construct $U \subseteq \mathbb{C}^n \otimes \mathbb{C}^n$ s.t.

$$H_{\min}^{(p)}(U \otimes U) < 2H_{\min}^{(p)}(U) \quad \text{and} \quad n = 2^{\tilde{O}\left(\frac{1}{p-1}\right)}$$

Main result: [Derksen-Lovitz 25]

For any $p > 1$, an explicit channel Φ on $\tilde{O}\left(\frac{1}{p-1}\right)$ qubits

such that

$$H_{\min}^{(p)}(\Phi \otimes \Phi) < 2H_{\min}^{(p)}(\Phi).$$

Proof ingredients:

- Channels \rightarrow Subspaces
- Useful bounds on $H_{\min}^{(p)}$
- Entangled subspace construction [Beauzamy+ 90]



Proof sketch: Bounds on $H_{\min}^{(p)}(U)$

Given subspace $U \subseteq \mathbb{C}^n \otimes \mathbb{C}^n$, let $\Lambda(U) := \max_{|\psi\rangle \in U} \lambda_{\max}(\psi_B)$

Suppose $|\psi\rangle = \sum_{i=1}^r \sqrt{\lambda_i} |i\rangle \otimes |i\rangle$.

$$\lambda_{\max}(\psi_B) = \lambda_1 = \max_{|u\rangle, |v\rangle \in \mathbb{C}^n} |\langle \psi | u \otimes v \rangle|^2$$

Hence,

$$\Lambda(U) = \max_{|\psi\rangle \in U} \max_{|u\rangle, |v\rangle \in \mathbb{C}^n} |\langle \psi | u \otimes v \rangle|^2$$

So: $\Lambda(U) = 1 \iff U$ contains a product state

Proof sketch: Bounds on $H_{\min}^{(p)}(U)$

Given subspace $U \subseteq \mathbb{C}^n \otimes \mathbb{C}^n$, let $\Lambda(U) := \max_{|\psi\rangle \in U} \lambda_{\max}(\psi_B)$

Suppose $|\psi\rangle = \sum_{i=1}^r \sqrt{\lambda_i} |i\rangle \otimes |i\rangle$.

$$\lambda_{\max}(\psi_B) = \lambda_1 = \max_{|u\rangle, |v\rangle \in \mathbb{C}^n} |\langle \psi | u \otimes v \rangle|^2$$

Hence,

$$\Lambda(U) = \max_{|\psi\rangle \in U} \max_{|u\rangle, |v\rangle \in \mathbb{C}^n} |\langle \psi | u \otimes v \rangle|^2 = \max_{|u\rangle, |v\rangle \in \mathbb{C}^n} \|\Pi_U(|u\rangle \otimes |v\rangle)\|^2$$

So: $\Lambda(U) = 1 \iff U$ contains a product state

For later!

Proof sketch: Bounds on $H_{\min}^{(p)}(U)$

Given subspace $U \subseteq \mathbb{C}^n \otimes \mathbb{C}^n$, let $\Lambda(U) := \max_{|\psi\rangle \in U} \lambda_{\max}(\psi_B)$

$$\frac{1}{1-p} \log(\Lambda(U)^p + (1 - \Lambda(U))^p) \stackrel{1}{\leq} H_{\min}^{(p)}(U) \stackrel{2}{\leq} \frac{p}{1-p} \log(\Lambda(U))$$

Proofs: Let $\rho \in D(B)$ with eigenvalues $\lambda_1 \geq \dots \geq \lambda_n$

$$2: \quad H^{(p)}(\rho) = \frac{1}{1-p} \log(\sum_{i=1}^n \lambda_i^p) \leq \frac{1}{1-p} \log(\lambda_1^p) = \frac{p}{1-p} \log(\lambda_1)$$

$$1: \quad H^{(p)}(\rho) = H^{(p)} \begin{pmatrix} \lambda_1 & & \\ & \ddots & \\ & & \lambda_n \end{pmatrix} \geq H^{(p)} \begin{pmatrix} \lambda_1 & & \\ & 1 - \lambda_1 & \\ & & \mathbf{0} \end{pmatrix} = \frac{1}{1-p} \log(\lambda_1^p + (1 - \lambda_1)^p)$$

Schur-concavity of $H^{(p)}$

Proof sketch: Bounds on $H_{\min}^{(p)}(U)$

Given subspace $U \subseteq \mathbb{C}^n \otimes \mathbb{C}^n$, let $\Lambda(U) := \max_{|\psi\rangle \in U} \lambda_{\max}(\psi_B)$

$$\frac{1}{1-p} \log\left(\Lambda(U)^p + (1 - \Lambda(U))^p\right) \stackrel{1}{\leq} H_{\min}^{(p)}(U) \stackrel{2}{\leq} \frac{p}{1-p} \log(\Lambda(U))$$

Lemma: [Hayden 07] $\Lambda(U \otimes U) \geq \frac{\dim(U)}{n^2}$

Proof sketch: Choose ONB $|u_1\rangle, \dots, |u_\ell\rangle$ of U .

$$\Lambda(U \otimes U) = \max_{\substack{|\mu\rangle \in U \otimes U \\ |\phi\rangle \in B \otimes B \\ |\psi\rangle \in E \otimes E}} |\langle \mu | \phi \otimes \psi \rangle|^2 .$$

$$\text{Let } |\mu\rangle = \frac{1}{\sqrt{\ell}} \sum_{i=1}^{\ell} |u_i\rangle \otimes |u_i\rangle, \\ |\phi\rangle = |\psi\rangle = \frac{1}{\sqrt{n}} \sum_{j=1}^n |jj\rangle$$

Proof sketch: Bounds on $H_{\min}^{(p)}(U)$

Given subspace $U \subseteq \mathbb{C}^n \otimes \mathbb{C}^n$, let $\Lambda(U) := \max_{|\psi\rangle \in U} \lambda_{\max}(\psi_B)$

$$\frac{1}{1-p} \log\left(\Lambda(U)^p + (1 - \Lambda(U))^p\right) \stackrel{1}{\leq} H_{\min}^{(p)}(U) \stackrel{2}{\leq} \frac{p}{1-p} \log(\Lambda(U))$$

Lemma: [Hayden 07] $\Lambda(U \otimes U) \geq \frac{\dim(U)}{n^2}$

$$H_{\min}^{(p)}(U \otimes U) \stackrel{2}{\leq} \frac{p}{1-p} \log\left(\frac{\dim(U)}{n^2}\right) \stackrel{!}{<} \frac{2}{1-p} \log\left(\Lambda(U)^p + (1 - \Lambda(U))^p\right) \stackrel{1}{\leq} 2H_{\min}^{(p)}(U)$$

Note: For **!** to hold, need $\Lambda(U)$ small and $\dim(U)$ large.

Proof sketch: Bounds on $H_{\min}^{(p)}(U)$

Given subspace $U \subseteq \mathbb{C}^n \otimes \mathbb{C}^n$, let $\Lambda(U) := \max_{|\psi\rangle \in U} \lambda_{\max}(\psi_B)$

$$\frac{1}{1-p} \log\left(\Lambda(U)^p + (1 - \Lambda(U))^p\right) \stackrel{1}{\leq} H_{\min}^{(p)}(U) \stackrel{2}{\leq} \frac{p}{1-p} \log(\Lambda(U))$$

Lemma: [Hayden 07] $\Lambda(U \otimes U) \geq \frac{\dim(U)}{n^2}$

$$H_{\min}^{(p)}(U \otimes U) \stackrel{2}{\leq} \frac{p}{1-p} \log\left(\frac{\dim(U)}{n^2}\right) \stackrel{!}{<} \frac{2}{1-p} \log\left(\Lambda(U)^p + (1 - \Lambda(U))^p\right) \stackrel{1}{\leq} 2H_{\min}^{(p)}(U)$$

Thm*: [D-L 25] For any $\epsilon > 0$, explicit $U \subseteq \mathbb{C}^n \otimes \mathbb{C}^n$ with

$$\Lambda(U) \leq 1 - \epsilon \quad \text{and} \quad \dim(U) = (1 - \epsilon)n^2$$

[D-L 25] \Rightarrow !:

$$p \log(1 - \epsilon) \stackrel{!}{>} 2 \log(\epsilon^p + (1 - \epsilon)^p) \iff (1 - \epsilon)^p \stackrel{!}{>} (\epsilon^p + (1 - \epsilon)^p)^2 \quad \checkmark \text{ for } \epsilon \rightarrow 0^+$$

Main result: [Derksen-Lovitz 25]

For any $p > 1$, an explicit channel Φ on $\tilde{O}\left(\frac{1}{p-1}\right)$ qubits

such that

$$H_{\min}^{(p)}(\Phi \otimes \Phi) < 2H_{\min}^{(p)}(\Phi).$$

Proof ingredients:

- Channels \rightarrow Subspaces
- Useful bounds on $H_{\min}^{(p)}$
- Entangled subspace construction [Beauzamy+ 90]



Proof sketch: The construction

Thm*: [D-L 25] For any fixed $\epsilon > 0$, explicit $U \subseteq \mathbb{C}^n \otimes \mathbb{C}^n$ with
 $\Lambda(U) \leq 1 - \epsilon$ and $\dim(U) = (1 - \epsilon)n^2$

Symmetric subspace: $S^d(\mathbb{C}^a) \subseteq (\mathbb{C}^a)^{\otimes d}$

Set of $|\psi\rangle$ for which $|\psi\rangle_{i_1, \dots, i_d} = |\psi\rangle_{i_{\sigma(1)}, \dots, i_{\sigma(d)}}$ for any permutation $\sigma \in \mathfrak{S}_d$

Example: $S^2(\mathbb{C}^a) = \{|\psi\rangle \in \mathbb{C}^a \otimes \mathbb{C}^a : |\psi\rangle_{ij} = |\psi\rangle_{ji} \text{ for all } i, j = 1, \dots, n\}$

Note: $S^{2d}(\mathbb{C}^a) \subseteq S^d(\mathbb{C}^a) \otimes S^d(\mathbb{C}^a)$.

Proof sketch: The construction

Thm*: [D-L 25] For any fixed $\epsilon > 0$, explicit $U \subseteq \mathbb{C}^n \otimes \mathbb{C}^n$ with
 $\Lambda(U) \leq 1 - \epsilon$ and $\dim(U) = (1 - \epsilon)n^2$

Symmetric subspace: $S^d(\mathbb{C}^a) \subseteq (\mathbb{C}^a)^{\otimes d}$

Set of $|\psi\rangle$ for which $|\psi\rangle_{i_1, \dots, i_d} = |\psi\rangle_{i_{\sigma(1)}, \dots, i_{\sigma(d)}}$ for any permutation $\sigma \in \mathfrak{S}_d$

Let $U = S^{2d}(\mathbb{C}^a)^\perp \subseteq S^d(\mathbb{C}^a) \otimes S^d(\mathbb{C}^a)$

$B = E = S^d(\mathbb{C}^a)$

Lemma: [Beauzamy+ 90] $\Lambda(U) \leq 1 - \binom{2d}{d}^{-1}$

Thm pf sketch: *Assuming $\epsilon = \binom{2d}{d}^{-1}$ for some d :

Note $n = \dim(S^d(\mathbb{C}^a)) = \binom{a+d-1}{d}$. $\dim(U) = n^2 - \binom{a+2d-1}{2d} \xrightarrow{a \rightarrow \infty} (1 - \epsilon)n^2$



Proof sketch: The construction

Thm*: [D-L 25] For any fixed $\epsilon > 0$, explicit $U \subseteq \mathbb{C}^n \otimes \mathbb{C}^n$ with
 $\Lambda(U) \leq 1 - \epsilon$ and $\dim(U) = (1 - \epsilon)n^2$

Symmetric subspace: $S^d(\mathbb{C}^a) \subseteq (\mathbb{C}^a)^{\otimes d}$

Set of $|\psi\rangle$ for which $|\psi\rangle_{i_1, \dots, i_d} = |\psi\rangle_{i_{\sigma(1)}, \dots, i_{\sigma(d)}}$ for any permutation $\sigma \in \mathfrak{S}_d$

Let $U = S^{2d}(\mathbb{C}^a)^\perp \subseteq S^d(\mathbb{C}^a) \otimes S^d(\mathbb{C}^a)$

$B = E = S^d(\mathbb{C}^a)$

Lemma: [Beauzamy+ 90] $\Lambda(U) \leq 1 - \binom{2d}{d}^{-1}$

Where does this lemma come from?

$$S^d(\mathbb{C}^a) \cong \mathbb{C}[x_1, \dots, x_a]_d$$

$$|\psi\rangle \mapsto p_\psi(x) = \langle \psi | x^{\otimes d} \rangle$$

[Beauzamy+ 90] original statement: $\|p \cdot q\| \geq \binom{2d}{d}^{-1/2} \|p\| \|q\|$ for all $p, q \in \mathbb{C}[x_1, \dots, x_a]_d$

Proof of Beauzamy+ lemma

Lemma: [Beauzamy+90] Let $U = S^{2d}(\mathbb{C}^a)^\perp \subseteq S^d(\mathbb{C}^a) \otimes S^d(\mathbb{C}^a)$.

$$\text{Then } \Lambda(U) \leq 1 - \binom{2d}{d}^{-1}$$

Proof sketch:

Let $\Pi_{2d} := \text{proj}(S^{2d}(\mathbb{C}^a)) = I - \Pi_U$

Note that:

$$\begin{aligned} \min_{|\phi\rangle, |\psi\rangle \in S^d(\mathbb{C}^a)} \|\Pi_{2d}(|\phi\rangle \otimes |\psi\rangle)\|^2 &= 1 - \max_{|\phi\rangle, |\psi\rangle \in S^d(\mathbb{C}^a)} \|\Pi_U(|\phi\rangle \otimes |\psi\rangle)\|^2 \\ &= 1 - \Lambda(U) \end{aligned}$$

So, equivalent to prove: $\min_{|\phi\rangle, |\psi\rangle \in S^d(\mathbb{C}^a)} \|\Pi_{2d}(|\phi\rangle \otimes |\psi\rangle)\|^2 \geq \binom{2d}{d}^{-1}$

Proof of Beauzamy+ lemma

Equivalent to prove: $\min_{|\phi\rangle, |\psi\rangle \in S^d(\mathbb{C}^a)} \|\Pi_{2d}(|\phi\rangle \otimes |\psi\rangle)\|^2 \geq \binom{2d}{d}^{-1}$

For $\sigma \in \mathfrak{S}_{2d}$, define $P_\sigma \in U((\mathbb{C}^a)^{\otimes 2d})$ as

$$P_\sigma |i_1 \cdots i_{2d}\rangle = |i_{\sigma^{-1}(1)} \cdots i_{\sigma^{-1}(2d)}\rangle$$

Note: $\Pi_{2d} = \frac{1}{(2d)!} \sum_{\sigma \in \mathfrak{S}_{2d}} P_\sigma$

Let $|x\rangle := |\phi\rangle \otimes |\psi\rangle$. Lemma: $\langle x | P_\sigma | x \rangle \geq 0$ for all $\sigma \in \mathfrak{S}_{2d}$.

Hence, $\|\Pi_{2d}(|\phi\rangle \otimes |\psi\rangle)\|^2 = \frac{1}{(2d)!} \sum_{\sigma \in \mathfrak{S}_{2d}} \langle x | P_\sigma | x \rangle \geq \frac{1}{(2d)!} \sum_{\sigma \in \mathfrak{S}_d \times \mathfrak{S}_d} \langle x | P_\sigma | x \rangle$

$$= \frac{1}{(2d)!} \sum_{\sigma \in \mathfrak{S}_d \times \mathfrak{S}_d} \langle x | x \rangle = \frac{d!d!}{(2d)!} = \binom{2d}{d}^{-1}$$



Comparison to randomized constructions

Thm: [Hayden-Winter 08] For any $p > 1$, randomized $V \subseteq \mathbb{C}^n \otimes \mathbb{C}^n$ s.t.

$$2H_{\min}^{(p)}(V) - H_{\min}^{(p)}(V \otimes V) = \log n - \mathcal{O}(1)$$

By contrast, our explicit $U \subseteq \mathbb{C}^n \otimes \mathbb{C}^n$ achieves only constant gap $\mathcal{O}(1)$: 

$$U = S^{2d}(\mathbb{C}^a)^\perp \subseteq S^d(\mathbb{C}^a) \otimes S^d(\mathbb{C}^a) \text{ contains } |u\rangle := \frac{1}{\sqrt{2}}(|0\rangle^d |1\rangle^d - |1\rangle^d |0\rangle^d)$$

$$|u\rangle \text{ has Schmidt rank 2, so } H_{\min}^{(p)}(U) \leq 1.$$

Does our construction satisfy $H_{\min}^{(1)}(U \otimes U) < 2 H_{\min}^{(1)}(U)$?

Typical randomized construction: [Hastings 09, Brandao-Hastings 10, Fukuda-King 10, Aubrun-Szarek-Werner 11]

Construct random $V \subseteq \mathbb{C}^{n_1} \otimes \mathbb{C}^{n_2}$ s.t. $n_2 = \alpha n_1^2$ and $\dim(V) = \beta n_2$ for const. α, β

satisfying $H_{\min}^{(1)}(V) \geq \log(n_1) - \mathcal{O}\left(\frac{1}{n_1}\right)$.

For our construction, $H_{\min}^{(1)}(U) \leq 1$ 😭

Then
$$\begin{aligned} H_{\min}^{(1)}(V \otimes V) &\leq (1 - \Lambda(V \otimes V)) \log(n_1^2 - 1) + h(\Lambda(V \otimes V)) && \text{by Schur-concavity} \\ &\leq 2 \left(1 - \frac{\beta}{\alpha n_1}\right) \log(n_1) + h\left(\frac{\beta}{\alpha n_1}\right) && \text{because } \Lambda(V \otimes V) \geq \frac{\dim(V)}{n_1 n_2} \\ &= 2 \log(n_1) - \Omega\left(\frac{\log n_1}{n_1}\right) \end{aligned}$$

So $2H_{\min}^{(1)}(V) - H_{\min}^{(1)}(V \otimes V) \geq \Omega\left(\frac{\log n_1}{n_1}\right) - \mathcal{O}\left(\frac{1}{n_1}\right) > 0$.

Extension: Multipartite Setting

For a subspace $U \subseteq (\mathbb{C}^n)^{\otimes m}$, let $\Lambda(U) := \max_{\substack{|\mu\rangle \in U \\ |\phi_i\rangle \in \mathbb{C}^n}} |\langle \mu | \phi_1 \otimes \cdots \otimes \phi_m \rangle|^2$

Thm*: [D-L 25] For any $\epsilon > 0$, explicit $U \subseteq (\mathbb{C}^n)^{\otimes m}$
with $\Lambda(U) \leq 1 - \epsilon$ and $\dim(U) = (1 - \epsilon)n^m$

Other apps: 1. Explicit robustly entangled mixed states.
2. Explicit entanglement witnesses with many highly neg e-values.

Conclusion

Main result: [Derksen-Lovitz 25]

For any $p > 1$, an explicit channel Φ on $\tilde{O}\left(\frac{1}{p-1}\right)$ qubits

such that

$$H_{\min}^{(p)}(\Phi \otimes \Phi) < 2H_{\min}^{(p)}(\Phi).$$

Question: Does this construction also work for $p = 1$?

We are hiring students and postdocs!

- CSSE dept, Concordia University
- Located in Montreal, Canada
- Please reach out if interested

